

# Operating Instructions

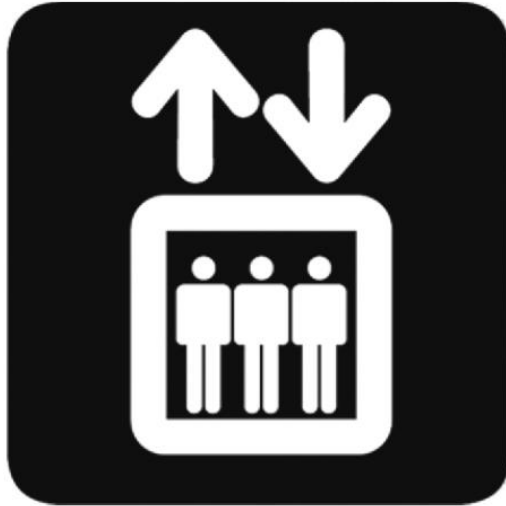

## **SQML** **Gearless Lift Motor**

## CONTENTS

<b>1- ABOUT SQML LIFT MOTORS</b>	<b>02</b>
<b>2-GENERAL INFORMATION</b>	<b>03</b>
2.1 Technical Support	03
2.2 General	03
<b>3- SAFETY</b>	<b>04</b>
3.1 General Remarks	04
3.2 General Warnings	04
3.3 User Responsibilities	05
3.4 Safety Instructions	05
<b>4-STORAGE and TRANSPORT</b>	<b>07</b>
4.1 Storage	07
4.2 Transport	07
<b>5- TECHNICAL INFORMATION</b>	<b>08</b>
5.1 EMF SQM100 Series	08
5.2 EMF SQM132 Series	08
5.3 EMF SQM160 Series	09
5.4 EMF SQM200 Series	09
5.5 Power Box Connection	10
5.6 Protection Class	11
5.7 Motor Plate Data	11
<b>6- INSTALLATION</b>	<b>12</b>
6.1 General	12
6.2 Recommendations for Installation	12
6.3 Mounting of the Motor	14
6.4 Mounting of Rope Protection Clamps	14
6.5 Encoder Connection	15
<b>7- COMMISSIONING</b>	<b>16</b>
7.1 Power Connection	16
7.2 Before Initial Start-up	18
7.3 Encoder Connection	18
7.4 Encoder Replacement	19
7.5 Mechanical Brake	21
7.6 Brake Test Procedure according to EN81-1	22
7.7 Brake Micro switch Test	23
7.8 Half-Load Test	23
7.9 Emergency Rescue	23
7.10 Safety Contactor Circuit (Braking circuit)	24
<b>8-SERVICE, MAINTENANCE and TROUBLESHOOTING</b>	<b>25</b>
8.1 Points to Take into Consideration During Service and Maintenance	25
8.2 Spare Parts	26
8.3 Maintenance Intervals	26
8.4 Problems, Causes and Solutions	27
8.5 Certifications	28

## **1- ABOUT SQML LIFT MOTORS**

SQML lift motors are designed for rope lifts used without reducers.

This machine consists of a torque motor with permanent magnets, a brake system, a sheave and feedback equipment.

Thanks to LiProKa principle, EMF lift motors have a precision control, a low noise level, a high travelling comfort and a very compact design.

EMF Motors are manufactured by our ISO 9001 certified company, using materials conforming TSE and DIN standards.

Thanks to the certified brake system, the cabin security level is high.

The technical data on the motor plate indicates the limits specified for the correct operation of the motor.

The life of the SQML motor is 20000 hours.

EMF reserves the right to make modification on any part of the motor in order to enhance safety and performance.

All product names and trademarks in this document are registered.

## 2-GENERAL INFORMATION

### 2.1 Technical Support

You can contact us about any matter.

EMF MOTOR	
Address	Ramazanođlu Mah. Sanayi Cad. No: 9 TR34906 Pendik / İSTANBUL /TÜRKİYE
Tel	+90 216 595 19 00
Fax	+90 216 595 19 01
E-mail	<a href="mailto:info@emfmotor.com">info@emfmotor.com</a>
Website	<a href="http://www.emfmotor.com">www.emfmotor.com</a>

### 2.2 General

This manual is prepared for the qualified personnel who plan, install, commission and service the lift system. This user manual contains important rules concerning personnel safety as well as security. Please read all the general safety warnings carefully and keep this user manual at a safe and easily accessible place for future reference.

The user is responsible for ensuring that the manual has been read and well understood by the employees in order to prevent any injury or damage and to ensure the safe operation of the motor.

EMF Motor San. ve Tic. A.Ş. shall not be liable for any damage or disruption caused by disregard of this manual.

The information in the manual can not be used or reproduced by third parties without permission. The copyright of the operation instructions of SQML lift motor belongs to EMF Motor San. ve Tic. A.Ş.

## 3- SAFETY

### 3.1 General Remarks

This manual contains important warnings concerning product safety as well as your own safety. Please read the 'General Safety Warnings' for the necessary safety precautions. Keep this manual at a safe place for easy access.

	<b>WARNING!</b> 'Warning' sign; motor can be damaged if necessary precautions are not taken.
---	---

	<b>CAUTION!</b> 'Caution' sign; you may suffer physical injuries if necessary precautions are not taken.
---	---

	<b>MECHANICAL HAZARD!</b> 'Mechanical Hazard' signs; work accidents may occur if ignored.
---	--

	<b>RISK OF ELECTRIC SHOCK!</b> 'Risk of electric shock' sign; work accidents may occur if ignored.
---	---

	<b>MAGNETIC FIELD WARNING</b> 'Magnetic field warning' sign; high magnetic field effect may arise if ignored.
---	--

	<b>INFORMATION</b> 'Information' signs contain recommendations for the user.
--	---

	<b>HIGH TEMPERATURE</b> 'High temperature' sign; burn hazard due to temperature on motor surface.
---	--

### 3.2 General Warnings

EMF motors can only be ready for use after being mounted on the platform where they will be used and the necessary safety precautions are taken. Installation, maintenance, and electrical connections can be made only by qualified personnel.



### **INFORMATION**

Read the operating instructions before the commissioning.

Safe, correct and proper installation of the motor is the responsibility of the lift company. Do not forget that the motors cause mechanical movement.

All the parts and installations of the lift must be designed, manufactured and installed in accordance with applicable norms and regulations for the reliable and safe operation of the motors.

### **3.3 User Responsibilities**

Mechanical and electrical issues, which have to be taken into consideration regarding commissioning, operating, maintenance and failures, are explained in the related sections of the manual.



### **MECHANICAL HAZARD!**

Do not forget that the motors cause mechanical movements! The rotating parts of the motor (e.g. rope and sheave) need to be enclosed as required to prevent possible accidents.



### **CAUTION!**

Unconscious use of EMF motors can pose a danger for people and equipment. Installation, commissioning, maintenance and repairs should be done only by trained personnel.

### **3.4 Safety Instructions**

No modifications that can alter the operation characteristics can be made on the general structure of the motor or on the brake. Tampering with the red sealed screws on the motor will void the guarantee. Such tampering can also hazardous conditions with respect to safety. No welding process shall be carried out on the motor, nor the motor shall be used as an grounding point for a welding process. This may damage the bearings and magnets of the motor. The motors must be kept free from excessive pollution and mechanical strain.



### **WARNING!**

Do not use a damaged motor.

If you receive a damaged motor, please contact the transport company.

Excessive pollution, dust, chips, oil, water and similar liquids can cause negative effects on the motor and the brake assembly. Therefore, the motors must be cleaned regularly, and the surface of the motor must be protected against such effects.

The motor must not be connected directly to the main power grid without a driver! The motor must be connected to a suitable driver, and it shall never be operated without taking all safety precautions and making the necessary driver adjustments. All the metal parts of lift installations must be grounded. The grounding connection must be connected to the motor driver. The grounding line must absolutely be separate from the neutral line. The length of the motor cable shall not exceed 25 m.

	<p><b>CAUTION!</b> Driver (inverter) settings and identification of encoder angle must be carried out separately for each motor. Otherwise, dangerous and uncontrolled accelerations may occur.</p>
---	---

According to the national and international color code directives, the NEUTRAL line must be blue and the GROUND line must be green-yellow.

There is a risk of electric shock in cases of short circuits in the stator. The electrical system connected to the motor must be de-energized carrying out any work on the motor.

If there is a damage to the motor cables, the cables must not be touched until the power is cut off. The cables can only be changed after power is cut off.

Touching the body of the motor before it cools can cause burns. In case of extreme heating (100 °C) or abnormal noise during motor operation, deactivate the motor immediately. Check the possible motor failures section and contact with the manufacturer if necessary.

The surfaces of the motor must be kept clean. Insufficient heat transmission on motor surfaces may reduce the life of the motor. The motors can be damaged if necessary precautions are not taken. The motor heat sensor must absolutely be connected to the necessary protective circuit.

	<p><b>MAGNETIC FIELD WARNING</b> Strong Magnetic Field! The distance between the motor and persons who have cardiac pacemakers must be at least 0,5 m.</p>
---	--

Do not ignore the attractive force of the magnetic field and do not approach the motors with tools or devices that might be affected by the magnetic field (watches, digital devices, iron or steel tools).

## 4- STORAGE and TRANSPORT



### **WARNING!**

If any damage is observed on the motor, do not start the motor. Check the packing of the motor, and if you see any damage that might have occurred during transport, report the situation to the transport company. Shipping damages are not covered by our guarantee! Avoid excessive loads and vibrations.

### 4.1 Storage

Please pay attention to the storage warnings on the packaging. The storage areas must be moisture-free and thermally balanced. The storage must be away from chemical reactions. The motor must be kept in its original packaging and away from moisture to prevent rust until the installation.

The storage time should not be too long (Maximum 1 year is recommended). The brakes must be released and the shaft must be manually rotated before the installation.

### 4.2 Transport

Do not store or transport the SQML motor which is removed from its packaging.

Damaged packaging must be replaced immediately. If the motors aren't packed properly, then they won't be protected against sudden impacts. Dangerous and sudden actions can cause accidents.

Use safety shoes and gloves during transportation. Maximum weight that the personnel can carry must be considered. The motor and the equipments may be heavier than 13 kg. Please use only lifting equipment with sufficient capacity during loading, unloading and transport.

When you are lifting with the workshop hoist, only use the lifting eyelets on the block. Please pay attention not to damage the motor with ropes and chains during loading, unloading and transport, especially the brake and the encoder assembly must be protected against sudden impacts.



## 5- TECHNICAL INFORMATION

### 5.1 EMF SQML100 Series

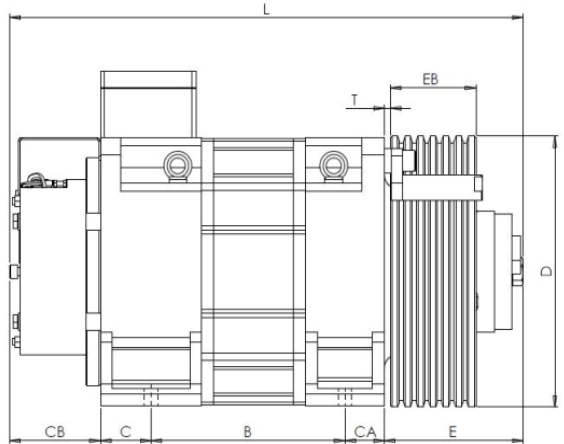
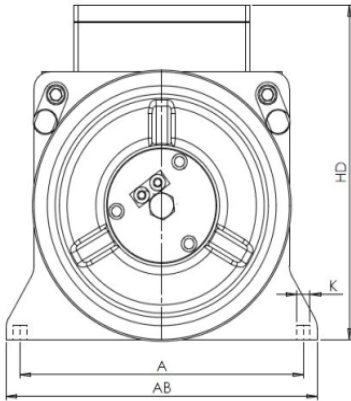

- For motor dimensions, please see Annex-A
- For actual motor dimensions, please visit [www.emfmotor.com](http://www.emfmotor.com).

### 5.2 EMF SQML132 Series

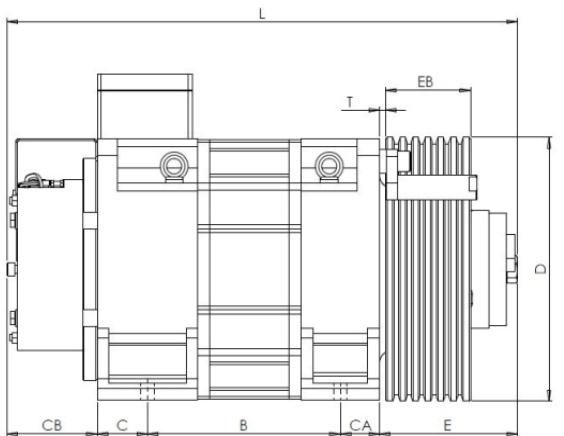
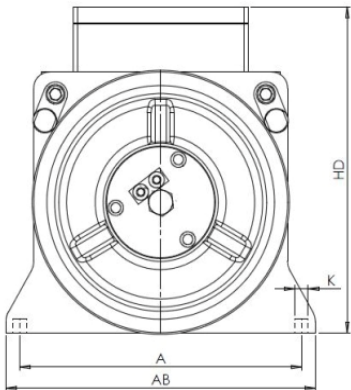

- For motor dimensions, please see Annex-A
- For actual motor dimensions, please visit [www.emfmotor.com](http://www.emfmotor.com).

### 5.3 EMF SQML160 Series

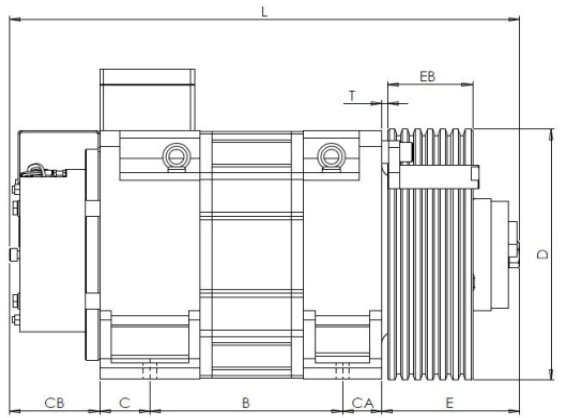
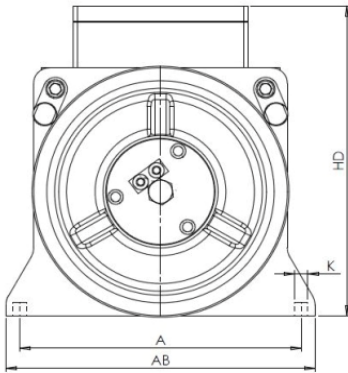

- For motor dimensions, please see Annex-A
- For actual motor dimensions, please visit [www.emfmotor.com](http://www.emfmotor.com).

### 5.4 EMF SQML200 Series

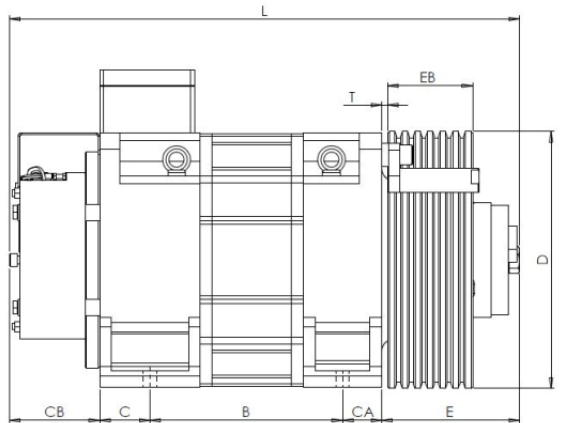
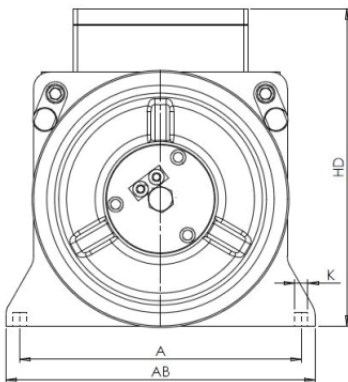

- For motor dimensions, please see Annex-A
- For actual motor dimensions, please visit [www.emfmotor.com](http://www.emfmotor.com).

## 5.5 Power Box Connection

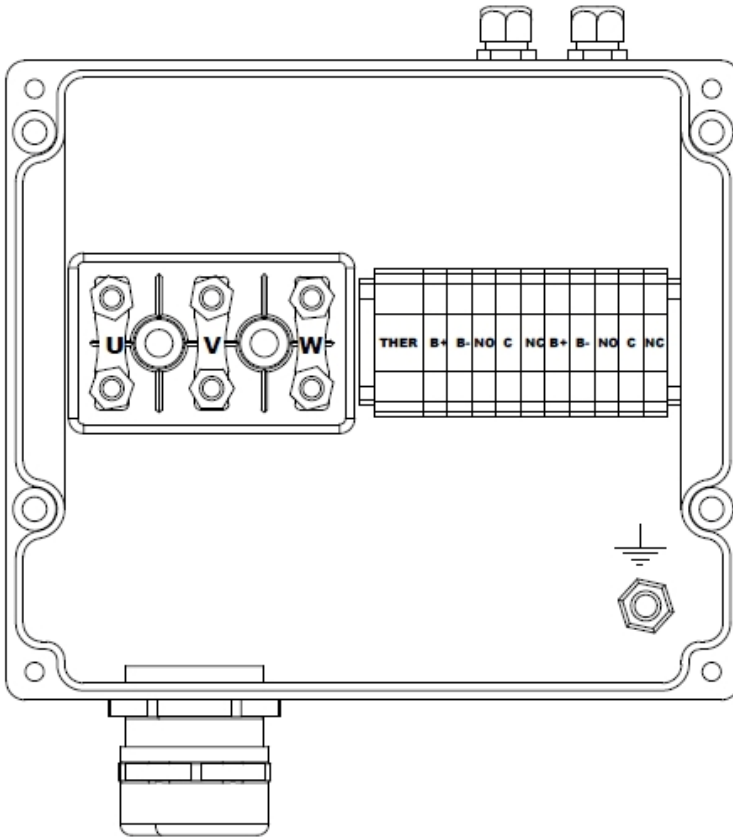

Drw-1

See 7.1 Power Connection

## 5.6 Protection Class

Motor	IP54
Encoder (mounted)	IP64
Brake (electrical)	IP54
Brake (mechanical)	IP10
Brake (micro switch)	IP67

## 5.7 Motor Plate Data



Made in TÜRKİYE

Designed in GERMANY

<b>TYPE</b> SQML160-2032H16080-2E2066	<b>S/N</b> 002948001			
<b>RATED TORQUE</b> 470 Nm	<b>RPM</b> 191 rpm	<b>DUTY</b> S3 %40	<b>CONNECT.</b> STAR	
<b>RATED CURRENT</b> 29,5 A	<b>POLES</b> 66	<b>KT</b> 15,93 Nm/A	<b>IP.CLASS</b> 21	
<b>RATED VOLTAGE</b> 325 V	<b>P</b> 9,4 kW	<b>FREQ</b> 05,05 Hz	<b>INS.CLASS</b> 180H	
<b>SHEAVE</b> 320 mm	<b>SHEAVE SPEED</b> 2:1 1,6 m/s		<b>FEEDBACK</b> ECN 413	
<b>MAX.LOAD</b> 800 kg	<b>MAX.ST.LOAD</b> 2800 kg	<b>BRAKE V</b> 207 VDC	<b>WEIGHT</b> 332 kg	

Drw-2

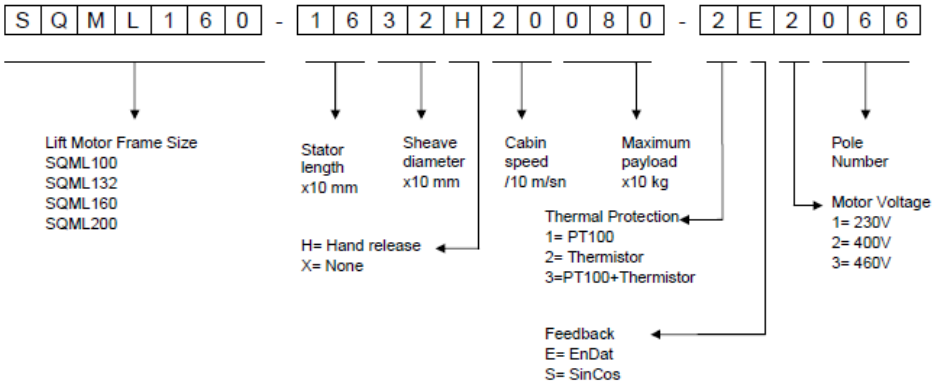

## 6- INSTALLATION

### 6-1 General

Contractor Company is responsible for all electrical connections, installation and commissioning of the motor. These operations must be carried out by trained personnel. Please contact EMF if you have any problems related with the motor.



#### **WARNING!**

Interventions on the lift motor and equipment will void the guarantee.

Before commencing the installation, the motor must be checked against transport damages.

The ambient temperature of the motor must be 0 °C - +40 °C, excessive humidity or water may cause motor failures.

The mechanical patented brake of the motor is TÜV (ABV 766 / 2) certified and its settings must be made at our factory. The customer shall not make any further adjustments.



#### **CAUTION!**

In case of any interventions on the setting screws on the brake, the brake may malfunction and cause safety problems. Any intervention on the motor brake will void the guarantee.

### 6.2 Recommendations for Installation

Motor and driver unit must be installed inside an appropriate structure or enclosed lift cabin, and they shall be positioned so as to prevent excessive dust, liquids (water, oil, etc) and foreign substances on the motor (See Chapter5.6). There must be sufficient space around the motor for air circulation. The distance between the motor and the wall must be 150 mm at least in order to access the encoder in case of need.

No welding process shall be carried out on the motor, nor the motor shall be used as an grounding point for a welding process. This may damage the bearings and magnets of the motor.



### **WARNING!**

The terminal box cover must be kept closed during the installation of the motor, because foreign objects could get in if the cover is open.

Suitable lifting equipment should be used when installing the motor. During the installation, lever, hammer and similar tools should not be used. Especially the encoder of the motor should not be subjected to impacts, because it has a sensitive electronic and mechanical structure. Also the motor shaft should not be subjected to sudden impacts. The motor can be connected horizontally or laterally. In case of lateral connection, the bottom part of the motor must be supported and fixing bolts must not be exposed to the shear force.

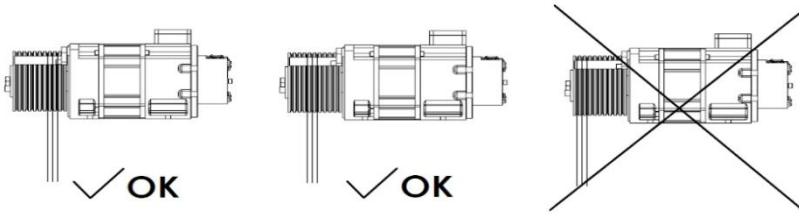

Drw-4

If the sheave has more rope channels than the actual number of ropes, the ropes must be in the middle canals of the sheave or the channels closest to the motor shall be used.

The electrical connection must be made according to the connection diagram (see Chapter 7.1). Motor supply and brake electrical cables must be laid inside a cable duct, and the encoder cable must be laid inside a separate cable duct. In order to prevent interference in encoder, it should not be laid side by side with the supply cables.



### **RISK OF ELECTRIC SHOCK!**

To prevent risk of fire or electric shocks, never expose the motor to rain or splashing water. Do not touch the motor with wet hands. Before carrying out any work on the motor, you must shut down the main supply circuit breaker of the system. Never intervene the cables while the motor and its driver are energized.

The supply cables to the motor must be grounded and shielded, the shielding and the grounding connection must be connected to the grounding of the motor.

### 6.3 Mounting of the Motor

The motor must be fixed to the platform with 4 bolts. These bolts must be used with lock washers.

Type SQML100... motors must be fixed to the working platform with 4 pcs M16 8.8 bolts. The tightening torque of the bolts is 210 Nm. The tightening depth of the fixing bolts must be 36 mm at least and 57 mm at most.

Type SQML132... motors must be fixed to the working platform with 4 pcs M16 8.8 bolts. The tightening torque of the bolts is 210 Nm. The tightening depth of the fixing bolts must be 36 mm at least and 57 mm at most.

Type SQML160... motors must be fixed to the working platform with 4 pcs M16 8.8 bolts. The tightening torque of the bolts is 210 Nm. The tightening depth of the fixing bolts must be 36 mm at least and 57 mm at most.

Type SQML200... motors must be fixed to the working platform with 4 pcs M18 8.8 bolts. The tightening torque of the bolts is 290 Nm. The tightening depth of the fixing bolts must be 36 mm at least and 57 mm at most.

The bolts must be tightened to the specified torques with a torque wrench. The fixing platform of the motor must be rigid and solid enough to withstand to the created force. The unevenness of the mounting surface shall not exceed 0,1 mm. Rubber cushions must be used during installation in order to dampen vibrations.

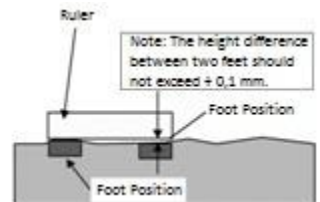

### 6.4 Mounting of Rope Protection Clamps

The sheave and diversion sheave are manufactured according to EN 81-1 standard. The rope selection must also be done according to EN81-1 standard.



#### **WARNING!**

Ropes that are used with 210-240 mm sheaves must be manufacturer certified.

The rope protection clamps prevent the ropes against slipping from the sheave. Rope protection clamps must be dismantled before the assembly of the ropes. The distance between the rope and the rope protection clamps must be adjusted to 2-3 mm and be fixed.

## 6.5 Encoder Connection

The motor must be operated with encoder feedback. Never operate the motor with a direct connection to the power grid!

The encoder behind the motor is supplied with a 5m signal cable. Encoder cable terminations are given below. The encoder entry of the motor driver used must be made as shown in the diagram and the shielding of the cable must be connected.

	<b>WARNING!</b>
	<p>In order to provide for the proper operation of the electronic circuit, check that the grounding of the motor and the driver complies with the appropriate standard. The building must have a separate grounding line and this grounding line must be connected to the system with a cable with correct cross-section.</p>

## ECN413 (EnDat) Connection Diagram

Pin layout for ECN 413

	Power supply					Inside shield	Incremental signals				Absolute position values			
	$U_p$	Sensor $U_p$	0V	Sensor 0V			A+	A-	B+	B-	DATA	$\overline{\text{DATA}}$	CLOCK	$\overline{\text{CLOCK}}$
	Brown/ Green	Blue	White/ Green	White	/	Green/ Black	Yellow/ Black	Blue/ Black	Red/ Black	Gray	Pink	Violet	Yellow	

**Shield** on housing;  $U_p$  = power supply voltage

**Sensor:** The sensor line is connected internally with the corresponding power line.

Vacant pins or wires must not be used!

$U_p$  : +5 VDC Supply



## ERN487 (SinCos) Connection Diagram

Pin layout for ERN 487

	Power supply					Incremental signals					
	U <sub>P</sub>	Sensor U <sub>P</sub>	0V	Sensor 0V	Inside shield	A+	A-	B+	B-	R+	R-
	Brown/ Green	Blue	White/ Green	White	/	Green/ Black	Yellow/ Black	Blue/ Black	Red/ Black	Red	Black

	Other signals			
	C+	C-	D+	D-
	Gray	Pink	Yellow	Violet

**Shield** on housing; U<sub>P</sub> = power supply voltage  
**C, D** = commutation signals for sinusoidal commutation  
**Sensor:** The sensor line is connected internally with the corresponding power line.  
 Vacant pins or wires must not be used!

U<sub>P</sub> : +5 VDC Supply

## 7- COMMISSIONING

Before commissioning, the installation of SQML lift motor must be completed with attention to the conditions described in the previous sections.

The specifications of the driver used must comply with the values specified on motor plate. Check the condition of the driver before connecting the power. In case of any failure, the driver must not be installed.

Ambient Conditions:

- Motor and driver must be installed inside an appropriate structure or enclosed lift cabin.
- The installation must comply with the protection class. The motor must be protected against falling of foreign materials (see Chapter 5-6).
- Do not operate the motor in explosive environments.
- The temperature must be between 0-40°C.
- Humidity ratio must not exceed 95% to prevent condensation.
- Altitude must not exceed 1000 m.

### 7.1 Power Connection

	<p><b>WARNING!</b></p> <p>The motor must not be connected to the main grid without a driver! When connecting to the motor driver, the U, V, W and motor grounding connections must be made with a shielded cable of proper cross-section and the shielding must be connected to the motor and driver.</p>
---	---

The maximum cable length is 25 m, when used with a cable of proper cross-section.

The U, V and W motor supply cables must be connected in the same sequence at both the motor and the driver side. Incorrect connection of the phases may lead to reverse rotation or uncontrolled movement of the motor.

The driver must switch the motor contactors while the drive does not apply current, and it must withdraw them before the motor is energized at restart. Otherwise, switching the motor contactors while the motor is energized, especially at zero speed, can cause failure of the driver and contactor.

According to customer's request, the motors are equipped with a PTO thermostatic switch (Klixon, 130 °C maximum electrical values 250VAC/2A/cos phi = 1). The thermal protection device of the motor must be connected to the safety circuit and it must stop the system in case the heat is above the limit level.



**WARNING!**  
 If the motor thermal protection is not connected to the safety system, thermal protection will not be activated in case of overheating of the motor. This situation can cause permanent damage on the motor.

The motor winding heat sensor and brake connections must be made according to the diagram given below.

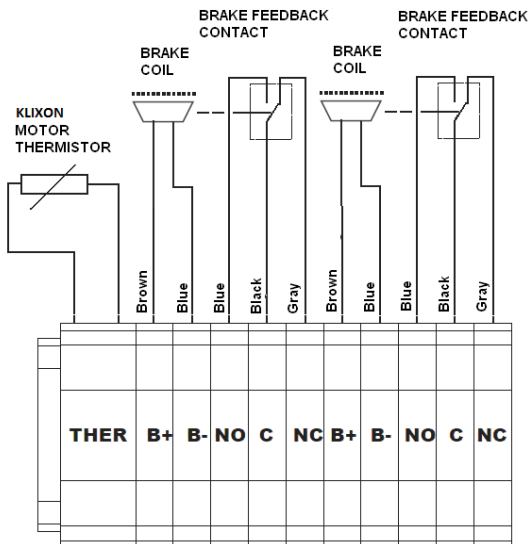

Drw-5

## 7.2 Before initial start-up

Before initial start-up, check the following.

- The mechanical installation and electrical connections must be properly completed.
- The brake supply circuit must be able to supply adequate voltage and current.
- The driver that feeds the motor must be able to supply adequate current and voltage, and the driver must be connected according to warnings specified in the operation instructions of the driver.
- The thermostatic switch of the motor must be connected correctly.
- Proper insulation and operating conditions must be provided.
- The motor must be mounted horizontally and according to the warnings specified in the related section.
- The safety circuits must be in operating condition.
- All leftover installation materials and other foreign materials must be removed.
- The safety contactor must be connected.
- The rope protection clamps must be connected and operating.
- The cable inlets must be sealed.
- The weights must be calculated according to the load values on the motor plate.
- The operating conditions must be in accordance with the information on the motor plate.
- In driver (inverter) settings, the encoder angle must be calculated by the driver, the motor should not be started before completing this procedure.

As well as the controls specified, the other controls required by the operating conditions must be carried out by authorized personnel.



### **WARNING!**

Encoder offset must be done rotational and without load on sheave. Otherwise motor can be damaged and warranty will be voided.

## 7.3 Encoder Connection



### **CAUTION!**

Remember that the phase order is directly related with the encoder angle. Any change in phase order will change encoder angle and this can cause uncontrolled motor operation and very high speeds.

The connection to the driver must be made according to the color codes in Encoder Connection diagram in Chapter 6.5. The shielding of the encoder cable must be

connected also to the driver side. A grounding fault in the system may harm the encoder and the driver.

Before operating the motor, the encoder offset angle must be determined in compliance with the procedures explained in the manual. The motor shall not be started before the encoder angle is identified by the driver.

Since the angle identified by the driver and the actual encoder angle will change during the mechanical disassembly/assembly process, the angle has to be identified again after such disassembly/assembly process.

If the length of the supplied 5 m cable will not be sufficient and an extension cable will be required, the cable joint must not be made by hand or with a simple electric terminal; it must be made with suitable connectors or by soldering. The extension cable to be used must have compatible properties and cross-section with the original cable of the encoder, and the isolation at the joints must be proper. Grounding connection must be made.

#### 7.4 Encoder Replacement:

The encoder must be replaced as explained below. Otherwise, a wrong connection can cause vibration, unstable working, uncontrolled movements and encoder failure.

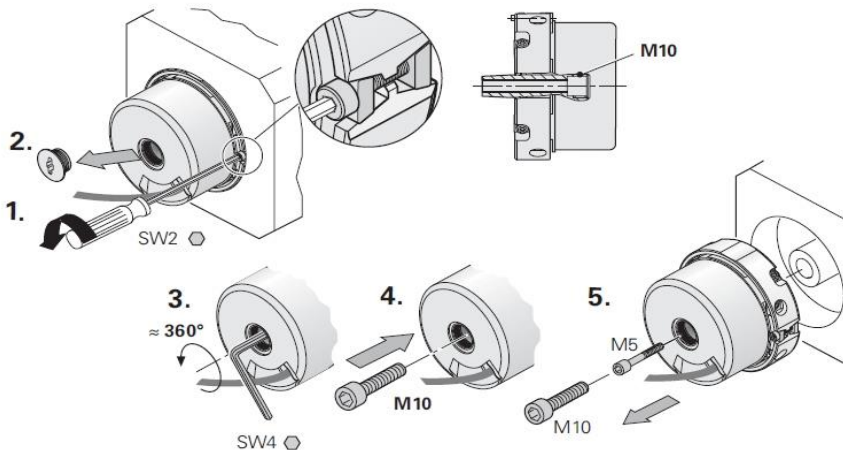

Drw-6

#### Dismounting Process:

- 1- Loosen the fixing frame of the encoder by using a 2 mm allen key.
- 2- Remove the protection cover of the encoder.
- 3- Loosen the fixing bolt (M5x47) of the encoder 1-2 turns by using a 4 mm allen key.
- 4- Use the M10x25 bolt as extractor and loosen the encoder.
- 5- Remove M5 bolt inside and take out the encoder from its slot.



### INFORMATION

During dismounting, do not manually force the encoder to remove.

### Mounting Process:

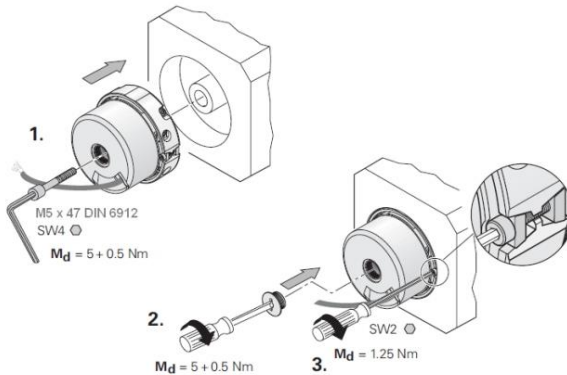

Drw-7

- 1- Place the encoder into its slot by hand and fix it by using M5x47 bolt. Manually check the forward – backward movement of the encoder and make sure that it does not move. (The tightening torque must be maximum 5 Nm.)
- 2- Fix the encoder protection cover.
- 3- Tighten the encoder frame bolt by using a 2 mm allen key, check the rotating movement by hand and make sure that it does not rotate. (The tightening torque must be maximum 1,25 Nm.)



### CAUTION!

After the new encoder is installed, the encoder offset angle must be readjusted via the driver. If it is not adjusted, this may cause uncontrolled motor operation and very high speeds.

**WARNING!**

Do not expose the encoder to excessive strain or impacts, because it is a sensitive electronic equipment.

**7.5 Mechanical Brake:**

The technical data concerning the brakes connected to EMF Motor is as follows. The brakes have two coils, and the voltage values are given for each coil separately.

The brakes operate in parallel with 207 VDC +/-10% (Overexcitation types 104VDC +/-10%) tolerance. To avoid overvoltage, varistors of appropriate capacity must be connected to the brake ends. Each brake coil has one micro switch and it should be connected to motor brake monitoring system with 'normally open' (NO) and 'normally closed' (NC) contact ends. Besides other safety precautions, the micro switches help the driver to decide whether or not to start the motor. If the brake is not open, it does not energize the driver motor and prevents the wear-out of the brake. If brake open command is received, then the driver must continue to control the motor.

**CAUTION!**

Replacement and maintenance procedures related with the mechanical brakes of the motor must be carried out by authorized personnel. Use of improper replacement parts may cause brake malfunctions. Improper use of or modifications on the electromagnetic brake, and neglecting the relevant safety standards and installation requirements may lead to hazardous consequences.

The mechanical brakes must activate when the motor is not moving. These electromagnetic brakes are designed static applications in synchronous lift motors. Since working braking is used, the wear on the brake linings will be at minimum level.

Operating the motor before releasing the brakes or activating the brakes before the motor stops may cause wear on the brake discs and loss of comfort. The brakes can operate with 60% working duty and 200 open/close cycles in an hour. The brakes must be operated in dry environments. If exposed to oil, dust, liquids, etc., a loss of torque may occur.



### **INFORMATION**

It is recommended to install an AC diode in brake open/close contactor coil supply circuit.

The operating temperature of the brakes is between  $-5\text{ }^{\circ}\text{C}$  -  $+45\text{ }^{\circ}\text{C}$ . The maximum brake temperature is  $+155\text{ }^{\circ}\text{C}$ .

## **7.6 Brake Test Procedure according to EN81-1:**

According to EN81-1 standard, the brake test must be carried out when the cabin is at the middle of the lift shaft.



### **CAUTION!**

The test procedure must be executed only by authorized and qualified personnel. All safety precautions must be taken during the test procedure.

### **Brake Test under Overload:**

The test should be carried out by interrupting the supply to the motor and the brake while the cabin is descending at rated speed with 125% of the rated load. During the test, the safety contactor circuit of the motor must be deactivated.

### **Single Brake Test:**

During single brake test, one of the brakes must be continuously kept open and must be able to control the other brake. Since one of the brakes will be continuously open, keep in mind that the safety circuit may prevent the operation of the system. During the test, the safety contactor circuit connected to the motor ends must be deactivated.

The test should be carried out by interrupting the supply to the motor and the brake while the cabin is descending at rated speed with rated load.



### **CAUTION!**

While performing this test, the lift must be observed continually. If there is no deceleration, the deactivated brake circuit has to be activated immediately! The necessary conditions must be provided for carrying out the test safely, and the necessary control buttons must be within easy reach in order to carry out the control actions explained!

## 7.7 Brake Micro switch Test

Check the brake micro switches. The Normally Open and Normally Closed contacts of the micro switches must be tested according to the safety system to be used and they must be set to deactivate the lift in case of any failure.

## 7.8 Half Load Test

Ascend and descend the cabin with half load; the measured currents at ascent and descent at the middle of the lift shaft shall not exceed 10 %.

## 7.9 Emergency Rescue



### **CAUTION!**

The emergency rescue operation must be performed only by authorized and qualified personnel.



### **INFORMATION**

In case of motors without reducers, the manual rescue action requires a very high force, since the force drop provided by the reducer is not available.

For rescue operations in case of power failure, the automatic rescue control located on the lift panel and carried out via the driver must be used. In this control system the driver is supplied from a UPS or a battery to bring the cabin to the nearest floor at low speed and to evacuate the passengers safely.

However, emergency rescue procedure must be performed if the above-mentioned system fails or is out of operation. This procedure is carried out with a portable power supply. The braking circuit connected to the motor phases must be activated and the mechanical brake must be withdrawn by means of the power supply and the cabin is moved toward the heavier direction in a controlled manner. During this procedure, the cabin must move at low speed. If an uncontrolled acceleration is observed, the mechanical brake must be activated immediately. During rescue procedure, the cabin speed must not exceed be under 0,63 m/s. See Chapter 7.10.

Mechanical rescue procedure can only be carried out when automatic rescue and portable power supply methods cannot be used and there is no other alternative for emergency rescue.



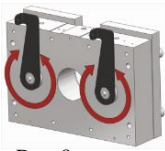

Drw-8

Mechanical rescue procedure must be carried out by authorized and qualified personnel, familiar with the lift system. Make sure that the safety contactor circuit connected to the motor cable ends in operation during mechanical rescue (see 7.10). Otherwise, the cabin will begin to accelerate towards the heavier direction in an uncontrolled manner.

The mechanical rescue must be carried out in a controlled manner by observing the cabin speed in order to prevent undesired movements. Before the rescue procedure, all necessary precautions must be taken considering the above situation.



**CAUTION!**

During mechanical rescue procedure, make sure that the braking circuit is connected and operating to prevent uncontrolled acceleration of the motor. If this braking circuit is not working properly, mechanical rescue procedure cannot be performed! Cabin should be observed during rescue procedure, even if the motor braking circuit is activated. In case of uncontrolled accelerations, the brake must be activated.



**CAUTION!**

Mechanical rescue branches must be kept at a safe place where unauthorized persons or persons from outside can not intervene. Otherwise, EMF Motor A.Ş. is not responsible for accidents that may occur.

## 7.10 Hand Release Brackets and Braking Circuit

Emergency rescue (bringing to floor) procedure must be carried out by means of motor and driver using a UPS or battery. In case of any fault in the system, the braking circuit must be used for the emergency rescue procedures to be carried out with motor brake when motor is not energized. This circuit is connected to the motor by means of a contactor.



**WARNING!**

**An additional circuit as shown in Drw. 10 must be used. Otherwise EMF motor is not responsible of any problem which may occur.**



### CAUTION!

Braking circuit must be tested by authorized personnel after installation. Brake rescue lever should be used carefully, the brake must be closed in case of sudden acceleration of the cabin. The emergency rescue procedure must be performed by authorized personnel. Periodic maintenance of brake circuit must be done once every 6 months.

**You can take technical support for braking circuit from EMF Motor.**

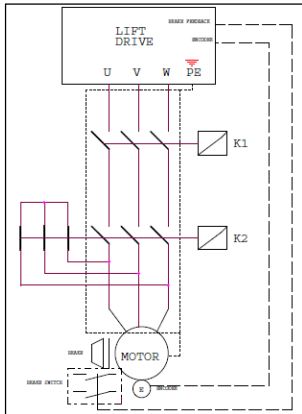

Drw-9 Classic braking circuit

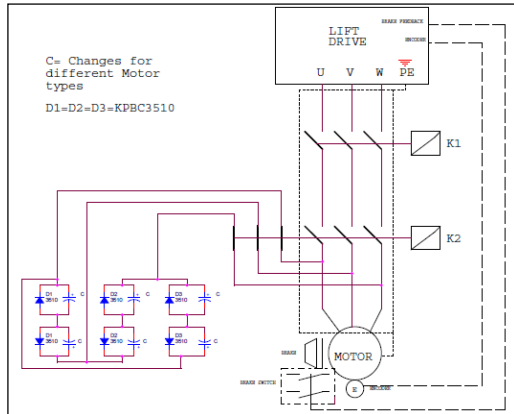

Drw-10 EMF Motor Braking Circuit

## 8- SERVICE, MAINTENANCE and TROUBLESHOOTING



### WARNING!

Flanges and bearings of the motor can be removed only by authorized personnel from EMF.



### WARNING!

Service and maintenance procedures must be carried out by authorized and qualified personnel.

### 8-1 Points to Take into Consideration During Service and Maintenance

Provide a safe working environment.

Never use high-pressure cleaners. No part of the motor requires lubrication.

Do not ignore abnormal noise during operation.

Control the safety and protection circuits.

## 8.2 Spare Parts



### WARNING!

Spare parts used in the motors are listed below. Original spare parts must be used in the motors. Otherwise, the guarantee of the motor will be void and our company will not be responsible for the damages that may occur.

Drw-11

Sheave  
 Brake System  
 Brake Micro  
 switches  
 Encoder  
 Rope Protection  
 Clamps

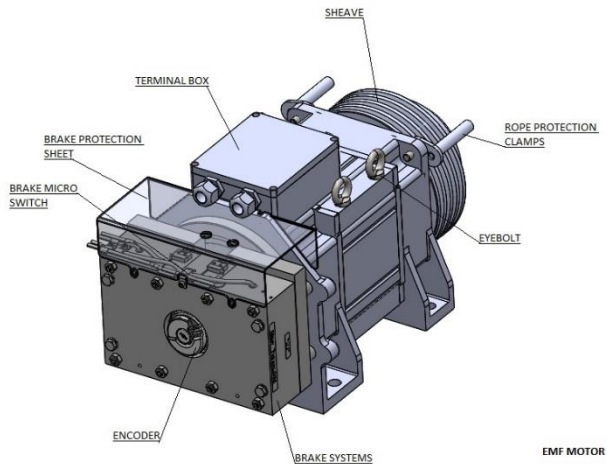

## 8.3 Maintenance Intervals

Distance of the rope protection clamp

: Every 3 months and every year.

Checking of the brake air gap

: Every 3 months and every year.

Visual inspection of the sheave and screws

: Every 3 months and every year.

Visual inspection of the mounting screws of the sheave and motor, and the mounting screws of the brake.

Wear and tear of the sheave

: Every Year



### INFORMATION

All the bolts and nuts on the motor, brake and sheave are sealed with paint. These seals help you to notice loose screws and nuts. If any bolt or nut is loose, such loosening must be eliminated by tightening at the specified torques. Broken sealing paint must be cleaned and re-sealed.

## 8.4 Problems, Causes and Solutions



### WARNING!

EMF Company will not assume any responsibility in the case that EMF lift motor is not commissioned properly, is not stored properly, is not maintained or modifications are made on the parts.

FAULT	CAUSES	REMEDY
Noises during operations.	Roller bearings are defective.	Ask for technical support.
	Driver settings are incorrect.	Check driver settings.
	Encoder is defective.	Replace the encoder.
Over temperature or thermal protection error.	Motor surface is not clean or is closed.	Remove the materials that prevent heat dissipation
	Ambient temperature is over 40°C	Ventilate the working place.
	Driver settings are incorrect.	Check driver settings.
Motor will not start	Motor phase connections are incorrect	Check motor power supply connections.
	Driver is defective.	Check driver.
	Brake doesn't release.	See the manual for brake problems.
Brake switching noises.	Check the DC voltage of brakes	Check brake supply circuit.
	Check driver settings.	Check brake opening and release times.
	Brake air gap is too high.	Brake disc is worn.
Brake does not release.	Brake supply voltage low.	Check brake supply and if any, supply transformer.
	Brake control circuit is defective.	Check brake connections.
	Brake coils are defective.	Replace the brake (Contact technical support)
	Brake is worn.	Replace brake disc (Contact technical support)
Brake monitor problem	Check the micro switch.	Replace the micro switches or the brake.
	Switch contacts are dirty.	Replace the micro switches or the brake.
Brake fail.	Braking circuit voltage not interrupted.	Check brake circuit.
	Brake linings are worn or dirty.	Replace the lining, air gap over 0,35 mm
	Brake spring settings are incorrect.	Replace the brake(Contact technical support )
Electric leakage on motor body.	Ground connection isn't proper.	Check grounding cable.
Motor draws overcurrent.	Brake doesn't fully release.	See the manual for brake problems.
	Motor phase connections are incorrect or loose	Check the connections of U, V, W phases in terminal box.
	Encoder angle miscalculated. Balance counterweight incorrect.	Carry out encoder angle determination procedure on the driver.

## EC DECLARATION OF CONFORMITY



Manufacturer **Elsim Elektroteknik Sistemler San. Ve Tic. A.Ş.**  
Address **Yeşilce Mah. Girne Cad. Çığdem Sok. No:4  
34418 – 4.Levent – İstanbul / TÜRKİYE**  
Mark **EMF**  
Product Name **Synchronous Torque Motor**  
Model **SQM - STM**  
Production Year **October 2010**

The products described below comply with the directives.

1. 89/336/EEC EC Council Directive 89/336/EEC as last European EMC Directive amended by EC Directive 2004/108/EC
2. 73/23/EEC Council Directive 73/23/EEC of 19 February 1973 on the Harmonization of the laws of Member States relating to electrical equipment designed for use within certain voltage limits
3. 2006/42/EC DIRECTIVE 2006/42/EC OF THE EUROPEAN PARLIAMENT AND OF THE COUNCIL of 17 May 2006

To which this declaration relates is in conformity with the following standards or other normative documents

TS 3205 EN 60034-1	TS EN 60034-9	TS EN 60034-11
TS EN 60034-18-1	TS 3033 EN 60529	TS EN 61000-4-3
TS EN 55011	TS 3206 EN 60034-2	TS EN 60034-14

This Declaration certifies the compliance with the indicated regulations, it doesn't guarantees attributes. Pay attention to the security advices of the relevant product information

By altering the device without approval the declaration would invalidate

Declaration Number **002**  
Representative for Conformity **Evren KAYAKIRAN**

Place and Date of issue **İstanbul, 07 October 2010**  
Signature



CERTIFICAT

CERTIFICADO

CЕРТИФИКАТ

認証証書

CERTIFICATE

ZERTIFIKAT



Industrie Service

## Type examination certificate

**Certificate no.:** ESV 766/1

**Certification office:** TÜV SÜD Industrie Service GmbH  
Westendstr. 199  
80686 München – Germany

**Applicant/  
certificate holder:** Chr. Mayr GmbH & Co. KG  
Eichenstr. 1  
87665 Mauerstetten - Germany

**Date of application:** 2010-06-17

**Manufacturer of the test sample:** Chr. Mayr GmbH & Co. KG  
Eichenstr. 1  
87665 Mauerstetten - Germany

**Product:** Braking element acting on the shaft of the traction sheave, as a part of the protection device against unintended car movement

**Type:** RSR/8010, \_\_\_\_\_, Größe 200 till 1500

**Test laboratory:** TÜV SÜD Industrie Service GmbH  
Prüflaboratorium für Produkte der Fördertechnik  
Prüfbereich Aufzüge und Sicherheitsbauteile  
Westendstr. 199  
80686 München – Germany

**Date and  
number of the test report:** 2011-07-07  
ESV 766/1

**Examination basis:** EN 81-1:1998 + A3:2009 (D), issue December 2009

**Result:** The safety component conforms to the requirements of examination basis for the respective scope of application stated on page 1 - 2 of the annex to this type-examination certificate.

**Date of issue:** 2011-07-11

Certification office for products of conveyor systems  
Lifts and safety components

*C. Rühmeyr*  
Christian Rühmeyr



TUV®

**Annex to the type-examination certificate  
no. ESV 766/1 dated 2011-07-11**

**1 Scope of application**

**1.1 Nominal brake torques and response times with relation to a brand-new brake element**

Name / Size	Minimum nominal brake torque* [Nm]	Maximum nominal brake torque* [Nm]	Maximum tripping rotary speed [rpm]	Maximum response times** [ms]		
				Parallel without overexcitation / Serial with overexcitation	$t_{50}$	$t_{90}$
200	2 x 100 = 200		820	100 / 110	160 / 230	230 / 330
200		2 x 280 = 560	820	25 / 30	60 / 80	110 / 135
200 „Lang“	2 x 250 = 500		820	25 / 30	50 / 65	110 / 135
200 „Lang“		2 x 350 = 700	820	15 / 20	30 / 50	80 / 100
400 „Kurz“	2 x 210 = 420		710	135 / 140	185 / 265	240 / 340
400 „Kurz“		2 x 420 = 840	710	50 / 55	90 / 130	160 / 230
400 „Kurz - leistungsoptimiert“		2 x 350 = 700	335	30 / 40	80 / 100	100 / 150
400 „Lang“	2 x 375 = 750		500	40 / 45	75 / 105	135 / 190
400 „Lang“		2 x 550 = 1100	500	25 / 40	60 / 75	100 / 120
600	2 x 500 = 1000		500	85 / 100	140 / 200	185 / 260
600		2 x 800 = 1600	500	30 / 40	70 / 100	120 / 170
800	2 x 650 = 1300		400	80 / 100	145 / 180	170 / 230
800		2 x 950 = 1900	400	35 / 45	80 / 115	120 / 160
1000	2 x 920 = 1840		400	80 / 95	125 / 180	180 / 250
1000		2 x 1200 = 2400	400	40 / 50	95 / 130	150 / 210
1500	2 x 1200 = 2400		400	75 / 90	160 / 190	270 / 310
1500		2 x 1800 = 3600	400	35 / 40	105 / 115	180 / 240

Interim values can be interpolated

**Explanations:**

\* **Nominal brake torque:**

Brake torque assured for installation operation by the safety component manufacturer.

\*\* **Response times:**

$t_x$  time difference between the drop of the braking power until establishing X% of the nominal brake torque,  $t_{50}$  optionally calculated  $t_{50} = (t_{10} + t_{90})/2$  or value taken from the examination recording

**1.2 Assigned execution features**

> Type of powering / deactivation	Continuous current / continuous current end
> Brake control	Parallel and serial
> Nominal air gap	0.45 mm
> Damping elements	YES
> Overexcitation (Größe 200 - 1000)	at 1.5 non-release voltage
> Overexcitation (Größe 1500)	at double non-release voltage

**Note:** The English text is a translation of the German original. In case of any discrepancy, the German version is valid only.  
2011-07-11:FS-A-MJC/we/ESV\_766-1\_Anh\_110711\_en

Page 1 of 2

## 2 Conditions

- 2.1 The above mentioned safety component represents only part of a protective equipment against unintended movement of the elevator car. Only in combination with a detecting and triggering component (two separate components also possible), which must be subjected to an own type examination, can the system created fulfill the requirements for a safety component in accordance with Annex F.8, EN 81-1:1998 + A3:2009 (D).
- 2.2 The safety component is used in combination with the brake device as part of the ascending car over-speed protection means and as a drive brake.
- 2.3 The installer of a lift must create an examination instruction in accordance with D.2 p) of EN 81-1:1998 + A3:2009 (D) for lift(s) to fulfil the overall concept, add it to the lift documentation and provide any necessary tools or measuring devices, which allow a safe examination (e. g., with closed shaft doors).
- 2.4 The dimension configuration of the lift system must be designed as regards the brake torques in such a way that the permissible value of deceleration does not exceed  $1 g_n$  in either direction. Excluded are decelerations, which are caused by an instantaneous roller safety gear up to a rated speed of the lift system of 0.63 m/s for instance.
- 2.5 The traction and its variance must be taken into account as regards its braking distance (transferable power / torque) and included in the calculation.
- 2.6 For installer of a lift, the compliance of the component with the type examined component and the assured nominal brake torques and response times must be confirmed in writing (e. g., type plate and/or supplement in the declaration of conformity).
- 2.7 The information evaluation for self-monitoring must prevent an operational starting of the lift in the event of a fault.
- 2.8 According to the norm requirements, the brake element of the protective device must impact directly on the drive disc or on the same shaft in the immediate vicinity of the drive disc.

If the brake element does not impact in the immediate vicinity of the brake disc on the same shaft, on which the drive disc is also arranged, a deviation from the norm exists. A failure of the shaft in the area between the drive disc and the brake element must be ruled out using corresponding construction designs and sufficient measurements. The manufacturer of the entire drive must prove the sufficient safety of the connection brake element – shaft and drive – shaft as well as the shaft itself in calculations. This proof must be added to the technical documentation of the lift.

## 3 Remarks

- 3.1 As part of the type examination, it was detected that the brake element has a redundant design and that the correct function is monitored by sensors.
- The examination of compliance with all requirements under Section 12.4 [EN 81-1:1998 + A3:2009 (D)], deterioration of the brake torques/braking forces due to wear and tear and the operation-related change of the drive capability are not part of this type examination.
- This type examination refers to the partial requirements for the protection device against unintended car movement only according to EN 81-1:1998 + A3:2009 (D), Section 9.11.
- 3.2 In order to provide identification, information about the basic design and functioning and to show the environmental conditions and connection requirements, drawing with the relevant latest identification from the associated EC type-examination certification ABV 766/X is to be enclosed with the type-examination certificate and the annex thereto.
- 3.3 The type-examination certificate may only be used in connection with the pertinent annex and the list of the authorized manufacturers (according to enclosure of the corresponding EC type-examination certification ABV 766/X).



CERTIFICAT

CERTIFICADO

СЕРТИФИКАТ

証書

CERTIFICATE

ZERTIFIKAT



Industrie Service

## EC type-examination certificate

**Certificate no.:** ABV 766/3

**Notified body:** TÜV SÜD Industrie Service GmbH  
Westendstr. 199  
80686 München - Germany

**Applicant/  
Certificate holder:** Chr. Mayr GmbH & Co. KG  
Eichenstr. 1  
87665 Mauerstetten - Germany

**Date of application:** 2011-02-08

**Manufacturer of the test sample:** Chr. Mayr GmbH & Co. KG  
Eichenstr. 1  
87665 Mauerstetten - Germany

**Product:** Braking device, acting on the shaft of the traction sheave, as part of the protection device against overspeed for the car moving in upwards direction

**Type:** RSR/8010\_ \_ \_ \_ \_ Größe 200, 400, 600, 800, 1000, 1500

**Test laboratory:** TÜV SÜD Industrie Service GmbH  
Prüflaboratorium für Produkte der Fördertechnik  
Prüfbereich Aufzüge und Sicherheitsbauteile  
Westendstr. 199  
80686 München - Germany

**Date and number of the test report:** 2011-04-14  
ABV 766/3

**EC-Directive:** 95 / 16 / EC

**Result:** The safety component conforms to the essential safety requirements of the Directive for the respective scope of application stated on page 1 - 2 of the annex to this EC type-examination certificate.

**Date of issue:** 2011-04-15

Certification body for lifts and safety components  
Identification number: 0036

C. Rührmayer  
Christian Rührmayer



TUV®

**Annex to the EC type-examination certificate  
no. ABV 766/3 dated 2011-04-15**

**1. Scope of Application**

- 1.1 Permissible brake moment, maximum tripping rotary speed and maximum rated rotary speed of the traction sheave when the brake device acts on the shaft of the traction sheave while the car is moving upward

Size	Permissible brake moment (Nm)	Max. tripping rotary speed of traction sheave (min <sup>-1</sup> )	Max. rated rotary speed of traction sheave (min <sup>-1</sup> )
200	200 – 560	811	705
200 „long“	500 – 700	820	713
400 „short“	420 – 840	708	616
400 „long“	750 – 1200	1011	879
600	1000 – 1600	500	435
800	1300 – 1900	400	348
1000	1840 – 2400	400	348
1500	2400 – 3600	400	348

- 1.2 Maximum tripping speed of the overspeed governor and maximum rated speed

The maximum tripping speed and the maximum rated speed must be calculated on the basis of the traction sheaves maximum tripping rotary speed and maximum rated rotary speed as outlined in sections 1.1 taking into account traction-sheave diameter and car suspension.

$$v = \frac{D \times \pi \times n}{60 \times i}$$

$v$  = speed (m/s)  
 $D$  = Diameter of the traction sheave from rope's centre to rope's centre (m)  
 $\pi$  = 3.14  
 $n$  = Rotary speed (min<sup>-1</sup>)  
 $i$  = Ratio of the car suspension

**2. Conditions**

- 2.1 Since the brake device represents only a part of the protection device against overspeed for the car moving in upwards direction an overspeed governor as per EN 81-1, paragraph 9.9 must be used to monitor the upward speed and the brake device must be triggered (engaged) via the overspeed governor's electric safety device.

Alternatively, the speed may also be monitored and the brake device engaged by a device other than an overspeed governor as per paragraph 9.9 if the device shows the same safety characteristics and has been type tested.

- 2.2 In order to recognise the loss of redundancy the movement of each brake circuit (each single brake) is to be monitored separately and directly (e.g. by micro switches, proximity switch). If a brake circuit fails to engage (close) while the lift machine is at standstill, next movement of the lift must be prevented.
- 2.3 In cases where the lift machine moves despite the brake being engaged (closed), the lift machine must be stopped at the next operating sequence at the latest and the next movement of the lift must be prevented. (The car may, for example, be prevented from traveling by querying the position of the micro switch, proximity switch which is used to monitor the mechanical movement of the brake circuits, should both brake circuits fail to open).

- 2.4 According to EN 81-1, paragraph 9.10.4 d a braking device must act directly on the traction sheave or on the same shaft on which the traction sheave is situated in the immediate vicinity thereof.

If the braking device does not act in the immediate vicinity of the traction sheave on the same shaft on which the traction sheave is situated, the standard is not complied with. In cases involving shaft failure in the extended area between the traction sheave and the braking device, safety would no longer be ensured by the latter if the lift car made an uncontrolled upward movement.

Shaft failure in the extended area must therefore be ruled out by appropriate design and sufficient dimensioning. In order to eliminate or reduce influencing factors which may lead to failure wherever possible, the following requirements must be satisfied:

- Minimization of bending length between traction sheave and braking device or traction sheave and the next bearing (the next bearing must form part of the drive unit)
- Static defined bearing (e. g. 2-fold borne shaft) otherwise measures are required to obtain a defined loading
- As far as possible, prevention of a reduction in load-bearing capacity in the area of reversed bending stress (reduction in load-bearing capacity caused, for example, by stress concentration and cross-sectional reductions)
- Between traction sheave and braking device the shaft must be continuous (made from one piece)
- Cross-sectional influences on the shaft are only permitted if they act on the following connections: traction sheave – shaft, braking device – shaft, torque of the transmitting component – shaft (situated between traction sheave and braking device).

The manufacturer of the drive unit must provide calculation evidence that the connection braking device – shaft, traction sheave - shaft and the shaft itself is sufficiently safe. If necessary, evidence must be provided for the intended measures, too (see static undefined bearing).

The calculation evidence must be enclosed with the technical documentation of the lift.

### 3. Remarks

- 3.1 A code number for the brake moment effectively adjusted will be marked at the first blank in the type designation 8010\_ \_ \_ \_ within the permissible scope of application. A code number for design characteristics which are not directly part of the type-examination will be marked at the rest of the blanks (e. g. in the second blank: with flange plate, in the third blank: with hand release, in the fourth blank: release control and/or wear control, in the fifth blank: characteristics for electrical connection).
- 3.2 The permissible brake moments must be applied to the lift system in such a manner that they do not decelerate more than  $1 g_m$  if the empty car is moving upwards.
- 3.3 In the scope of this type-examination it was found out, that the brake device also functions as a brake for normal operation, is designed as a redundant system and therefore meets the requirements to be used also as a part of the protection device against overspeed for the car moving in upwards direction.  
This type examination only refers to the requirements pertaining to brake devices as per EN 81-1, paragraph 9.10.  
Checking whether the requirements as per paragraph 12.4 have been complied with is not part of this type examination.
- 3.4 In order to provide identification, information about the basic design and functioning and to show the environmental conditions and connection requirements, drawing no. E 028 01 000 000 1 61 with certification stamp dated 2011-04-15 is to be enclosed with the EC type-examination certificate and the annex thereto.
- 3.5 The environment and connection conditions of the safety gear are described and depicted in additional documents (e. g. the assembly instructions).
- 3.6 The EC type-examination certificate may only be used in connection with the pertinent annex and the list of the authorized manufacturers (according to enclosure). This enclosure shall be updated and re-edited following information of the certificate holder.





**Annex to the type-examination certificate  
no. ESV 845 dated 2011-07-11**

**1 Scope of application**

**1.1 Nominal brake torques and response times with relation to a brand-new brake element**

Name / Size	Minimum nominal brake torque* [Nm]	Maximum nominal brake torque * [Nm]	Maximum tripping rotary speed [rpm]	Maximum response times** [ms]		
				t <sub>0</sub>	t <sub>50</sub>	t <sub>90</sub>
RTW 150	2 x 90 = 180		981	40	70	95
RTW 150		2 x 180 = 360	981	20	40	70
RTW 200	2 x 120 = 240		979	85	145	190
RTW 200		2 x 250 = 500	979	30	60	110
RTW 250	2 x 185 = 370		800	50	75	110
RTW 250		2 x 320 = 640	800	25	45	85
RTW 350	2 x 250 = 500		800	60	100	125
RTW 350		2 x 460 = 920	800	30	50	85

Interim values can be interpolated

**Explanations:**

- \* **Nominal brake torque:** Brake torque assured for installation operation by the safety component manufacturer.
- \*\* **Response times:** t<sub>0</sub> time difference between the drop of the braking power until establishing X% of the nominal brake torque, t<sub>50</sub> optionally calculated t<sub>50</sub> = (t<sub>10</sub> + t<sub>90</sub>)/2 or value taken from the examination recording

**1.2 Assigned execution features**

Type of powering / deactivation	Continuous current / continuous current end
Brake control	Parallel
Nominal air gap	0.45 mm
Damping elements	YES
Overexcitation	NO

**2 Conditions**

- 2.1 The above mentioned safety component represents only part of a protective equipment against unintended movement of the elevator car. Only in combination with a detecting and triggering component (two separate components also possible), which must be subjected to an own type examination, can the system created fulfil the requirements for a safety component in accordance with Annex F.8, EN 81-1:1998 + A3:2009 (D).
- 2.2 The safety component is used in combination with the brake device as part of the ascending car overspeed protection means and as a drive brake.

Note: The English text is a translation of the German original. In case of any discrepancy, the German version is valid only.  
2011.07-11/NS-FGA-MUC/wel/BS\_ESV845\_Arb\_110711\_EN

- 2.3 The installer of a lift must create an examination instruction in accordance with D.2 p) of EN 81-1:1998 + A3:2009 (D) for lift(s) to fulfil the overall concept, add it to the lift documentation and provide any necessary tools or measuring devices, which allow a safe examination (e. g., with closed shaft doors).
- 2.4 The dimension configuration of the lift system must be designed as regards the brake torques in such a way that the permissible value of deceleration does not exceed 1 g, in either direction. Excluded are decelerations, which are caused by an instantaneous roller safety gear up to a rated speed of the lift system of 0.63 m/s for instance.
- 2.5 The traction and its variance must be taken into account as regards its braking distance (transferable power / torque) and included in the calculation.
- 2.6 For installer of a lift, the compliance of the component with the type examined component and the assured nominal brake torques and response times must be confirmed in writing (e. g., type plate and/or supplement in the declaration of conformity).
- 2.7 The information evaluation for self-monitoring must prevent an operational starting of the lift in the event of a fault.
- 2.8 According to the norm requirements, the brake element of the protective device must impact directly on the traction sheave or on the same shaft in the immediate vicinity of the traction sheave.
- If the brake element does not impact in the immediate vicinity of the traction sheave on the same shaft, on which the traction sheave is also arranged, a deviation from the norm exists. A failure of the shaft in the area between the traction sheave and the brake element must be ruled out using corresponding construction designs and sufficient measurements. The manufacturer of the entire drive must prove the sufficient safety of the connection brake element – shaft and traction sheave – shaft as well as the shaft itself in calculations. This proof must be added to the technical documentation of the lift.

### 3 Remarks

- 3.1 As part of the type-examination, it was detected that the brake element has a redundant design and that the correct function is monitored by sensors.
- The examination of compliance with all requirements under Section 12.4 (EN 81-1:1998 + A3:2009 (D)), deterioration of the brake torques/breaking forces due to wear and tear and the operation-related change of the drive capability are not part of this type-examination.
- This type-examination refers to the partial requirements for the protection device against unintended car movement only according to EN 81-1:1998+A3:2009 (D), Section 9.11.
- 3.2 In order to provide identification, information about the basic design and functioning and to show the environmental conditions and connection requirements, drawing with the relevant latest identification from the associated EC type-examination certification ABV 845/X is to be enclosed with the type-examination certificate and the annex thereto.
- 3.3 The EC type-examination certificate may only be used in connection with the pertinent annex and the list of the authorized manufacturers (according to enclosure of the corresponding EC type-examination certification ABV 845/X).

CERTIFICAT

◆ CERTIFICADO

◆ СЕРТИФИКАТ

◆ 認証証書

◆ CERTIFICATE

ZERTIFIKAT



Industrie Service

## EC type-examination certificate

**Certificate no.:** ABV 845

**Notified body:** TÜV SÜD Industrie Service GmbH  
Westendstr. 199  
80686 München – Germany

**Applicant/  
Certificate holder:** Chr. Mayr GmbH & Co. KG  
Eichenstr. 1  
87665 Mauerstetten – Germany

**Date of application:** 2009-11-25

**Manufacturer of the test sample:** Chr. Mayr GmbH & Co. KG  
Eichenstr. 1  
87665 Mauerstetten – Germany

**Product:** Braking device, acting on the shaft of the traction sheave, as part of the protection device against overspeed for the car moving in upwards direction

**Type:** RTW Größe 150, 200, 250, 350  
Type 8012\_ \_ \_ \_ \_

**Test laboratory:** TÜV SÜD Industrie Service GmbH  
Prüflaboratorium für Produkte der Fordertechnik  
Prüfbereich Aufzüge und Sicherheitsbauteile  
Westendstr. 199  
80686 München – Germany

**Date and  
number of the test report:** 2010-03-09  
ABV 845

**EC-Directive:** 95 / 16 / EC

**Result:** The safety component conforms to the essential safety requirements of the Directive for the respective scope of application stated on page 1 - 2 of the annex to this EC type-examination certificate.

**Date of issue:** 2010-03-10

Certification body for lifts and safety components  
Identification number: 0036

*C. Rühmeyer*  
p. p. Christian Rühmeyer



TUV®



**Annex to the EC type-examination certificate  
no. ABV 845 dated 2010-03-10**

**1 Scope of application**

- 1.1 Permissible brake moment, maximum tripping rotary speed and maximum rated rotary speed of the traction sheave when the brake device acts on the shaft of the traction sheave while the car is moving upward.

Size	Permissible brake moment (Nm)	Max. tripping rotary speed of traction sheave (min <sup>-1</sup> )	Max. rated rotary speed of traction sheave (min <sup>-1</sup> )
150	180 – 360	981	853
200	240 – 500	979	851
250	370 – 640	800	696
350	500 – 920	800	696

- 1.2 Maximum tripping speed of the overspeed governor and maximum rated speed

The maximum tripping speed and the maximum rated speed must be calculated on the basis of the traction sheaves maximum tripping rotary speed and maximum rated rotary speed as outlined in sections 1.1 taking into account traction-sheave diameter and car suspension

$$v = \frac{D \times \pi \times n}{60 \times i}$$

$v$  = speed (m/s)  
 $D$  = Diameter of the traction sheave from rope's centre to rope's centre (m)  
 $\pi$  = 3,14  
 $n$  = Rotary speed (min<sup>-1</sup>)  
 $i$  = Ratio of the car suspension

**2 Conditions**

- 2.1 Since the brake device represents only a part of the protection device against overspeed for the car moving in upwards direction an overspeed governor as per EN 81-1, paragraph 9.9 must be used to monitor the upward speed and the brake device must be triggered (engaged) via the overspeed governor's electric safety device.
- Alternatively, the speed may also be monitored and the brake device engaged by a device other than an overspeed governor as per paragraph 9.9 if the device shows the same safety characteristics and has been type tested.
- 2.2 In order to recognise the loss of redundancy the movement of each brake circuit (each single brake) is to be monitored separately and directly (e.g. by micro switches). If a brake circuit fails to engage (close) while the lift machine is at standstill, next movement of the lift must be prevented.
- 2.3 In cases where the lift machine moves despite the brake being engaged (closed), the lift machine must be stopped at the next operating sequence at the latest and the next movement of the lift must be prevented. (The car may, for example, be prevented from travelling by querying the position of the micro switch which is used to monitor the mechanical movement of the brake circuits, should both brake circuits fail to open).

- 2.4 According to EN 81-1, paragraph 9.10.4 d a braking device must act directly on the traction sheave or on the same shaft on which the traction sheave is situated in the immediate vicinity thereof.
- If the braking device does not act in the immediate vicinity of the traction sheave on the same shaft on which the traction sheave is situated, the standard is not complied with. In cases involving shaft failure in the extended area between the traction sheave and the braking device, safety would no longer be ensured by the latter if the lift car made an uncontrolled upward movement.
- Shaft failure in the extended area must therefore be ruled out by appropriate design and sufficient dimensioning. In order to eliminate or reduce influencing factors which may lead to failure wherever possible, the following requirements must be satisfied:
- Minimization of bending length between traction sheave and braking device or traction sheave and the next bearing (the next bearing must form part of the drive unit)
  - Static defined bearing (e. g. 2-fold borne shaft) otherwise measures are required to obtain a defined loading
  - As far as possible, prevention of a reduction in load-bearing capacity in the area of reversed bending stress (reduction in load-bearing capacity caused, for example, by stress concentration and cross-sectional reductions)
  - Between traction sheave and braking device the shaft must be continuous (made from one piece)
  - Cross-sectional influences on the shaft are only permitted if they act on the following connections: traction sheave – shaft, braking device – shaft, torque of the transmitting component – shaft (situated between traction sheave and braking device).
- The manufacturer of the drive unit must provide calculation evidence that the connection braking device – shaft, traction sheave - shaft and the shaft itself is sufficiently safe. If necessary, evidence must be provided for the intended measures, too (see static undefined bearing).
- The calculation evidence must be enclosed with the technical documentation of the lift.

### 3 Remarks

- 3.1 The permissible brake forces must be applied to the lift system in such a manner, that the empty car moving in upwards direction is not decelerated by more than 1g.
- 3.2 In the scope of this type-examination it was found out, that the brake device also functions as a brake for normal operation, is designed as a redundant system and therefore meets the requirements to be used also as a part of the protection device against overspeed for the car moving in upwards direction.
- This type-examination only refers to the requirements pertaining to brake devices as per EN 81-1, paragraph 9.10.
- Checking whether the requirements as per paragraph 12.4 have been complied with is not part of this type-examination.
- 3.3 In order to provide identification, information about the basic design and functioning and to show the environmental conditions and connection requirements, drawing no. E028 12 200 000 1 81 dated 2010-03-03 and certification stamp dated 2010-03-10 is to be enclosed with the EC type-examination certificate and the annex thereto.
- 3.4 The environment and connection conditions of the safety gear are described and depicted in additional documents (e. g. the assembly instructions).
- 3.5 The EC type-examination certificate may only be used in connection with the pertinent annex and the list of the authorized manufacturers (according to enclosure). This enclosure shall be updated and re-issued following information of the certificate holder.

Note: The English text is a translation of the German original. In case of any discrepancy, the German version is valid only.

IS-FSA-MJ/Cng / 100310\_AnABV 845\_en

Page 2 of 2

